

Libera



*The elegant
solution*



FORMENTI &
GIOVENZANA



Giefte



FGV Slovakia, Spol s r.o.



FGVTN Brasil LTDA.



FGV Dongguan

Great Numbers, Great Value



FGV is the leading Italian manufacturer of furniture hardware and components. Since 1947 the company develops, produces and sells worldwide clever solutions for the furniture and kitchen industry at the right price. Over the years MADE IN FGV has become synonymous of Italian design combined with mass volume economies of scale.

True to its slogan “Great Numbers, Great Value”, FGV offers to the market the right products in the right quality at the right price.

With 4 production plants in Italy, Slovakia, Brazil and China working with the same quality standards, FGV has the tools to propose affordable solutions with the latest technologies.

Using state-of-the-art and cost efficient technology, FGV delivers a product portfolio which covers the needs of the industry. The FGV sales network of own subsidiaries is completed by a very performing net of strategic distributors to deliver modern furniture technology in every part of the world.

Investing constantly in Customer service and new logistics solutions, FGV aim to help the furniture and kitchen industry to deliver an improved experience to the end-consumer when these buying and using furniture or kitchen cabinets.



Formenti & Giovenzana S.p.A.





Libera

The elegant solution

High-end design for a trendy look

Modern colour finishes

Outstanding performances

SlowMotion and OneTouch technologies



The **Libera** hinge represents the latest solution in the FGV hinge program. The high-end product design confers an elegant look to the whole furniture. Available for wooden and aluminium framed door applications in two different colour finishes (Black and Nickel) to emphasized an aesthetical modern appeal. Unique functional features and outstanding performances with Libera and Libera XL versions.



High-end design

The Libera hinge, with its high-end design, is an elegant and attractive solution for furniture with modern appeal. The discrete and compact presence, completely integrated into the top and bottom cabinet panels, guarantee a non-invasive and freestyle look.

Modern and trendy applications

Available in Nickel and Black colour finishes to guarantee a perfect matching with modern and trendy furniture both with wooden or aluminium framed door applications.



Libera and Libera XL

No limits to door dimensions, with Libera and Libera XL versions is covered a complete weight range of doors from 16 to 30 kg.

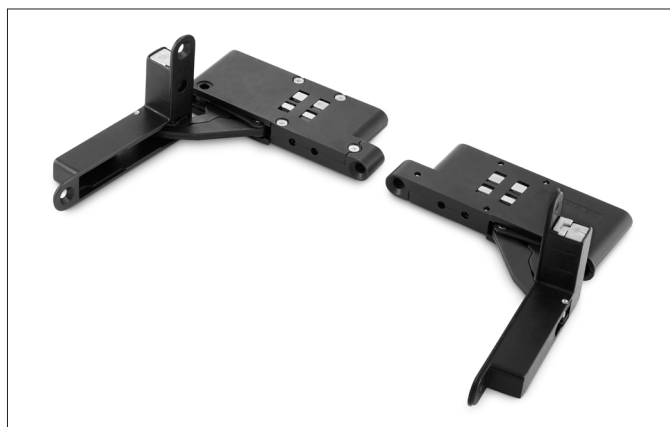

All the benefits from the up-to-date technologies

Available with SlowMotion technology for a soft door closure and smooth movement in every condition. Push-to-open application with OneTouch technology for self-opening of handle-less doors with linear and clear design.



A perfect door alignment

Thanks to an integrated 3D-adjustment it is possible to guarantee the right alignment of the door laterally, in height and in depth.





Technical specifications:

- Depth of the metal box 17mm
- Opening 100°
- Possibility of wooden door drilling (K) from 3 to 6 mm
- Thickness of the wooden door (T) 20mm minimum

LIBERA XL



SLOWMOTION VERSION

<u>Code</u>	<u>Description</u>	<u>Packing</u>
51.0AS2.**.010X.000	Left/Down (or Right/Up) SlowMotion hinge	30 pcs
51.0AS2.**.020X.000	Left/Up (or Right/Down) SlowMotion hinge	30 pcs

** Metal colour code: 03 = Black / 05 = Nickel

INTERFER

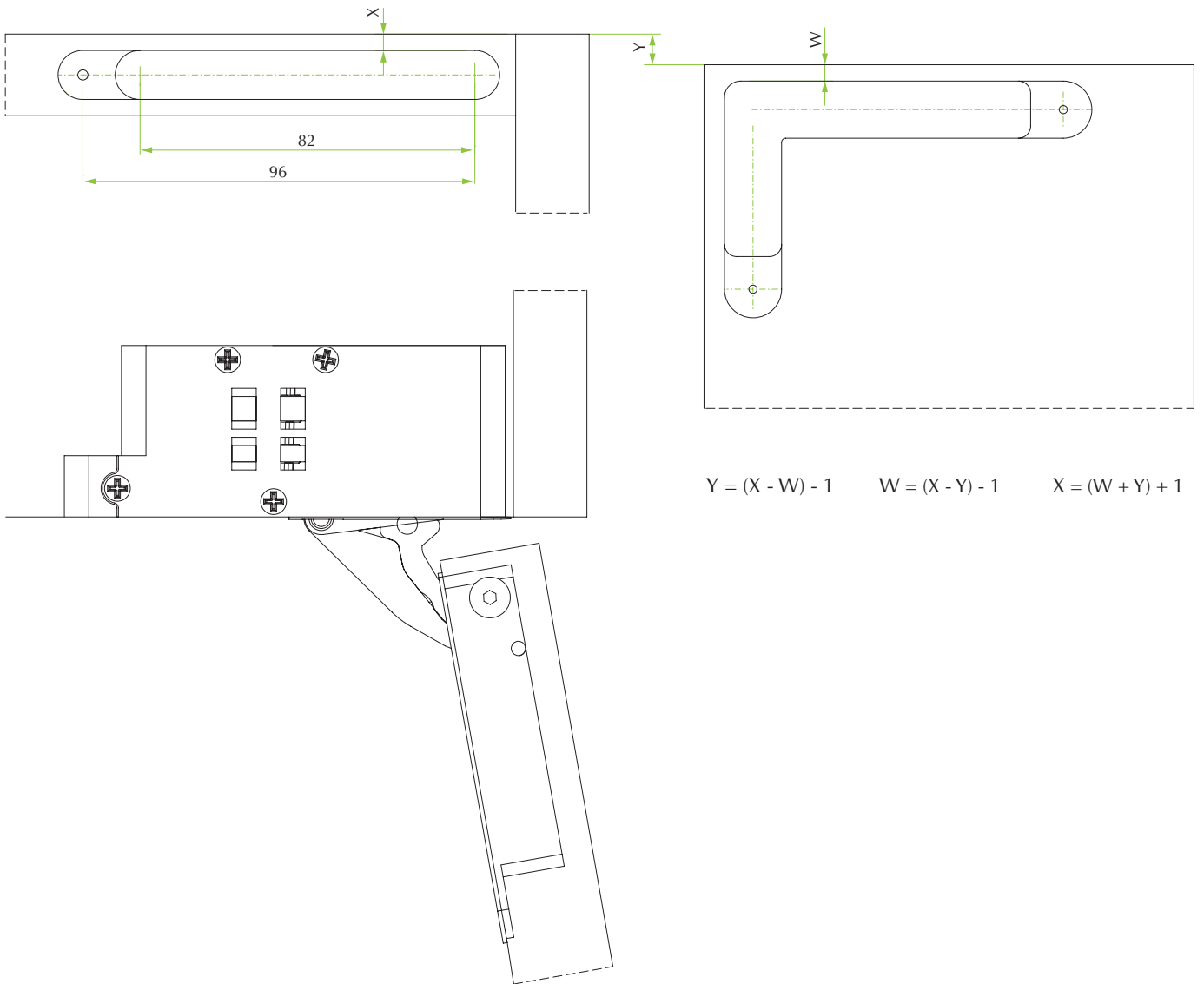
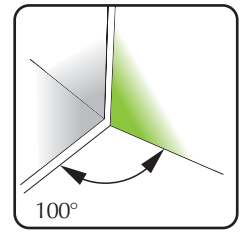
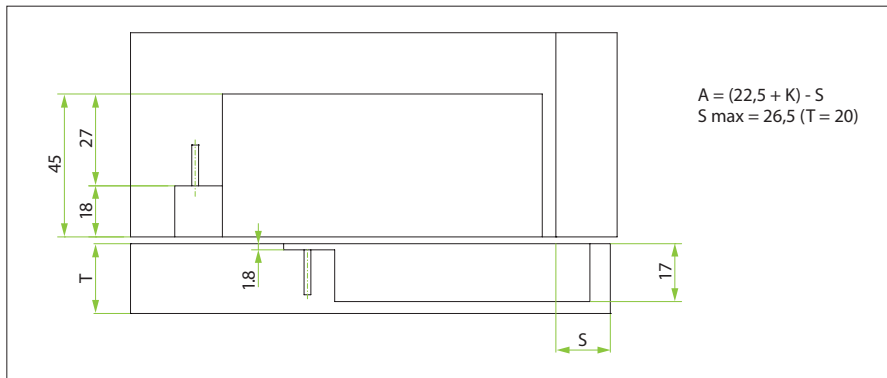
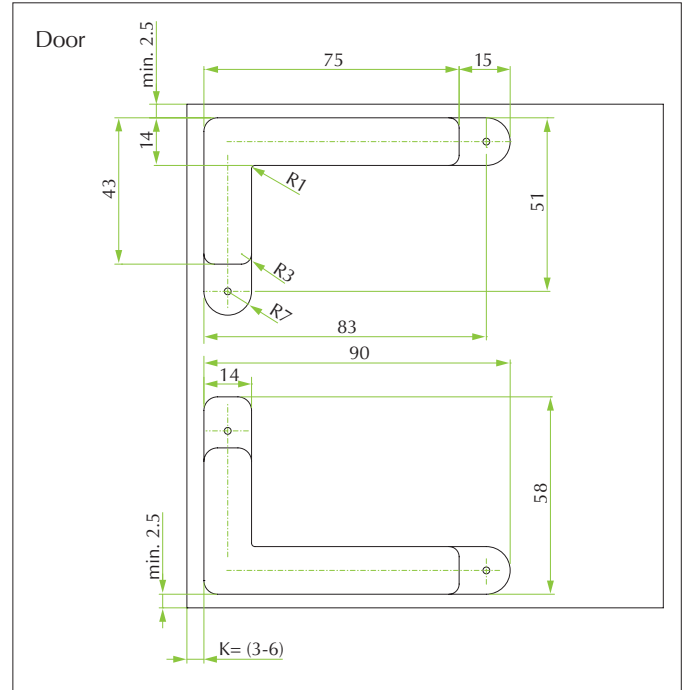
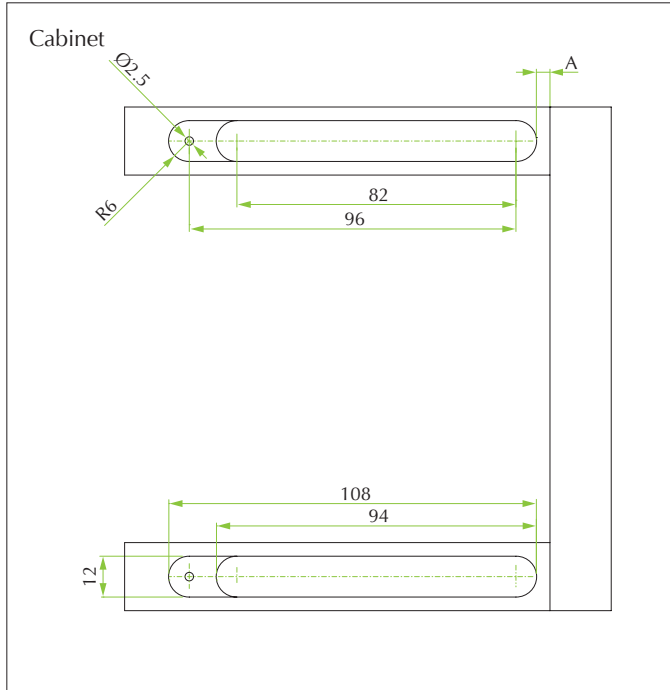

Table to determinate the minimum distance A so that a door with T thickness can open without protrusion from the cabinet and without interfering with adjacent doors.

T=	20	22	24	26	28	30	32	34	36	38	40
K=3 A=	0	0	0	0	0	0.5	1	1.8	2.9	4.3	5.8
K=4 A=	0	0	0	0	0.2	0.5	1	1.8	2.8	4.0	5.5
K=5 A=	0	0	0	0	0.2	0.5	1	1.8	2.6	3.8	5.1
K=6 A=	0	0	0	0	0.2	0.5	1	1.8	2.5	3.6	4.8

Instructions for INTERFERera XL

Wooden door application



Aluminium door application

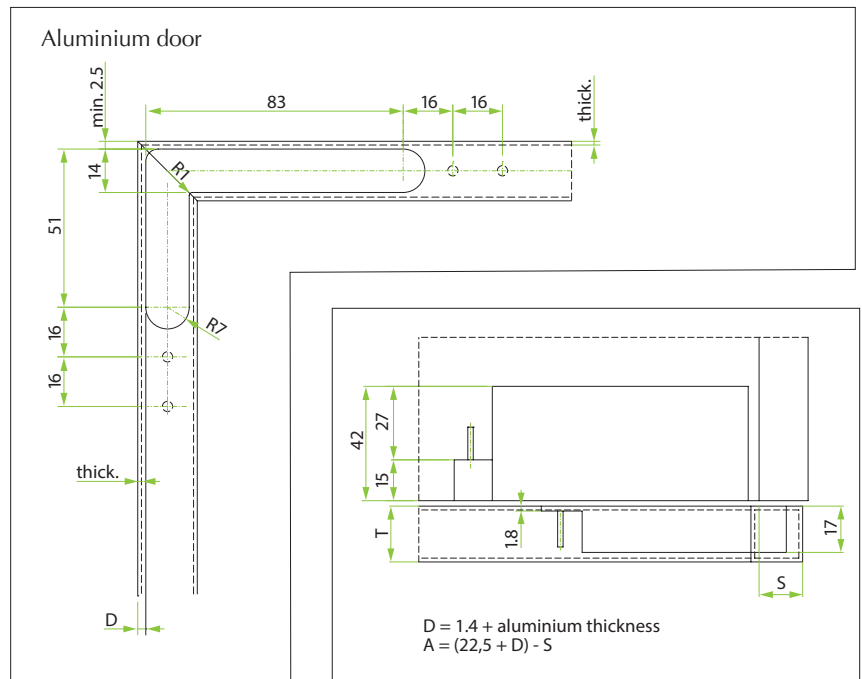
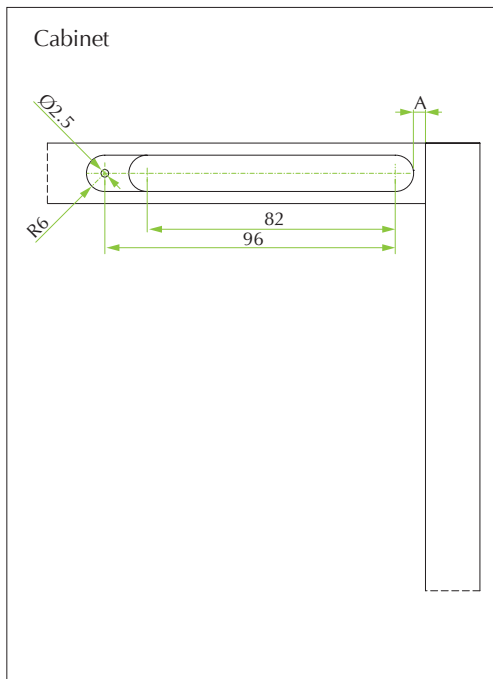

Adjustments

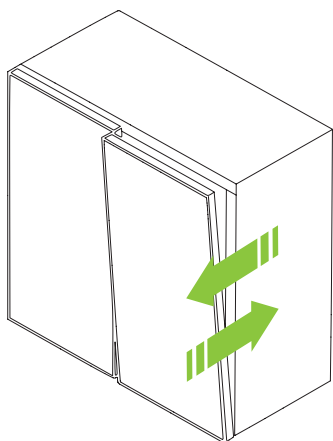

Frontal adjustments $\pm 2/-0.5$ mm

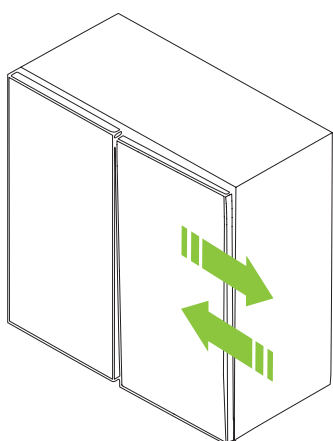
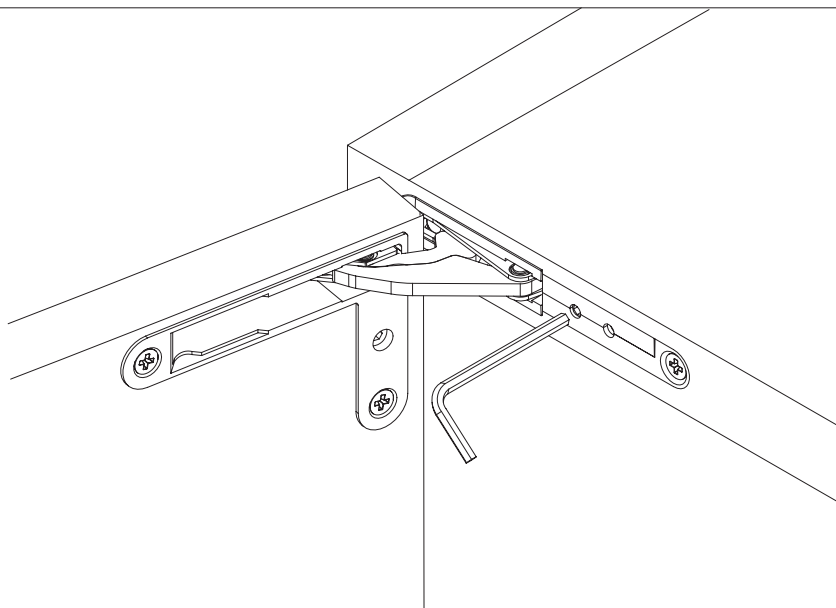

Lateral adjustments $\pm 2/-2$ mm

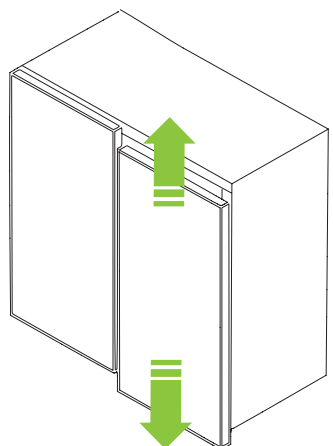
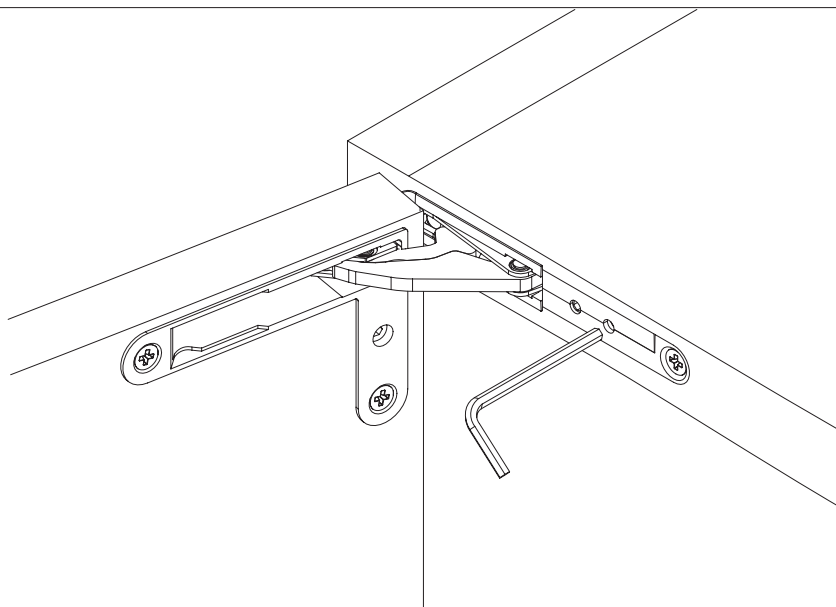

Vertical adjustments $\pm 2/-2$ mm

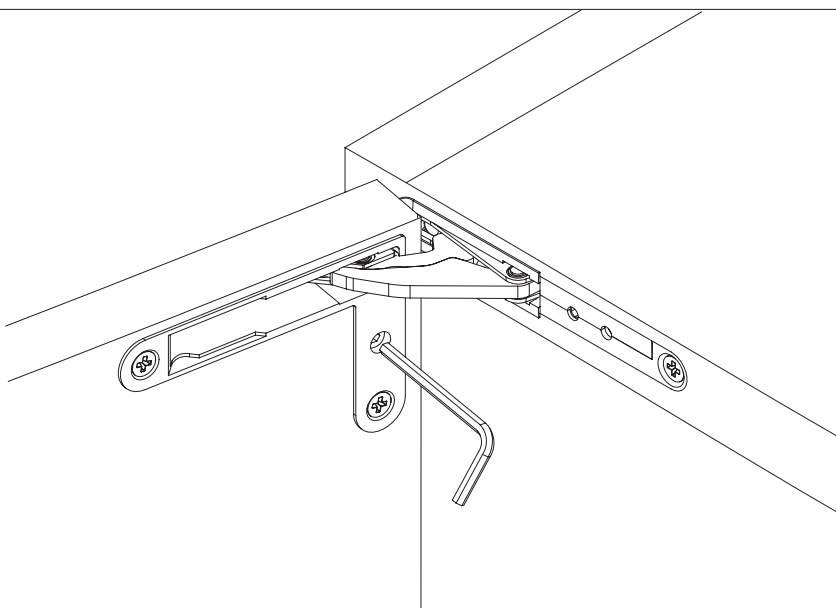



Technical specifications:

- Depth of the metal box 15mm
- Opening 105°
- Possibility of wooden door drilling (K) from 3 to 6 mm
- Thickness of the wooden door (T) 18mm minimum

LIBERA



SLOWMOTION VERSION

Code	Description	Packing
51.0AS1.**.KT0X.000	Set of Up and Down SlowMotion hinges	50 sets
51.0AS1.**.010X.000	Left/Down (or Right/Up) SlowMotion hinge	100 pcs
51.0AS1.**.020X.000	Left/Up (or Right/Down) SlowMotion hinge	100 pcs

ONE-TOUCH VERSION

Code	Description	Packing
51.0AS1.**.KT0P.000	Set of Up and Down OneTouch hinges	50 sets
51.0AS1.**.010P.000	Left/Down (or Right/Up) SlowMotion hinge	100 pcs
51.0AS1.**.020P.000	Left/Up (or Right/Down) SlowMotion hinge	100 pcs

VERSION WITHOUT SPRING

Code	Description	Packing
51.0AS1.**.KT00.000	Set of Up and Down hinges	50 sets
51.0AS1.**.0100.000	Left/Down (or Right/Up) hinge	100 pcs
51.0AS1.**.0200.000	Left/Up (or Right/Down) hinge	100 pcs

** Metal colour code: 03 = Black / 05 = Nickel

Packing in set consisting of 1 box with: 1 bag of 50 Up hinges and 1 bag of 50 Down hinges.
Cover Cap available see page 17.

INTERFER

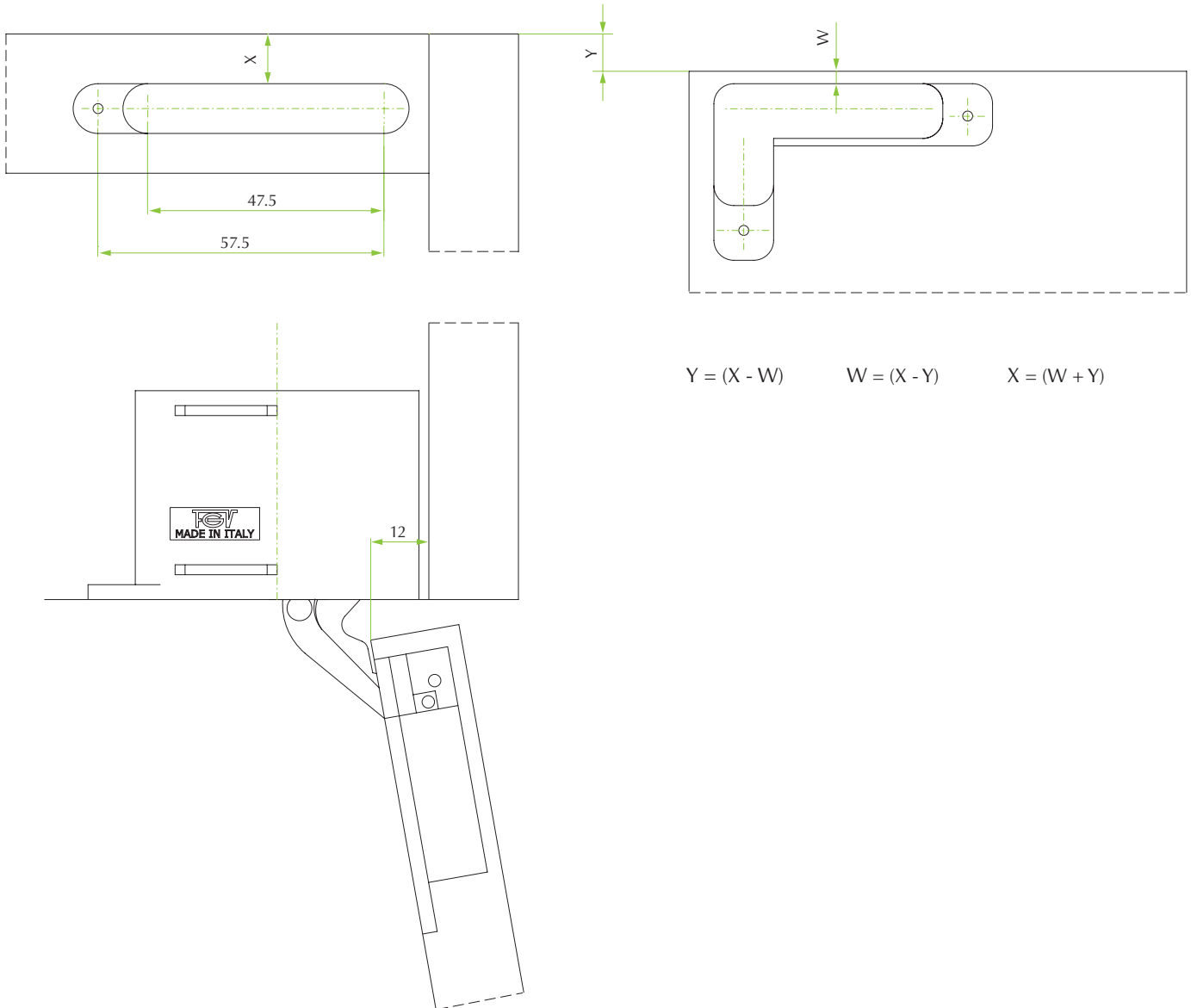
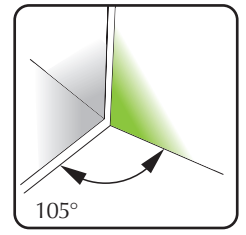
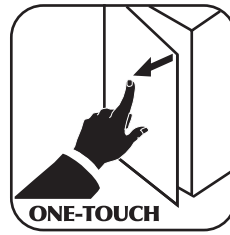
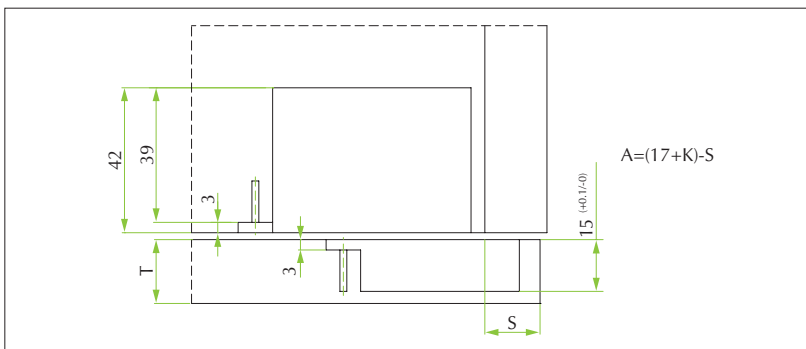
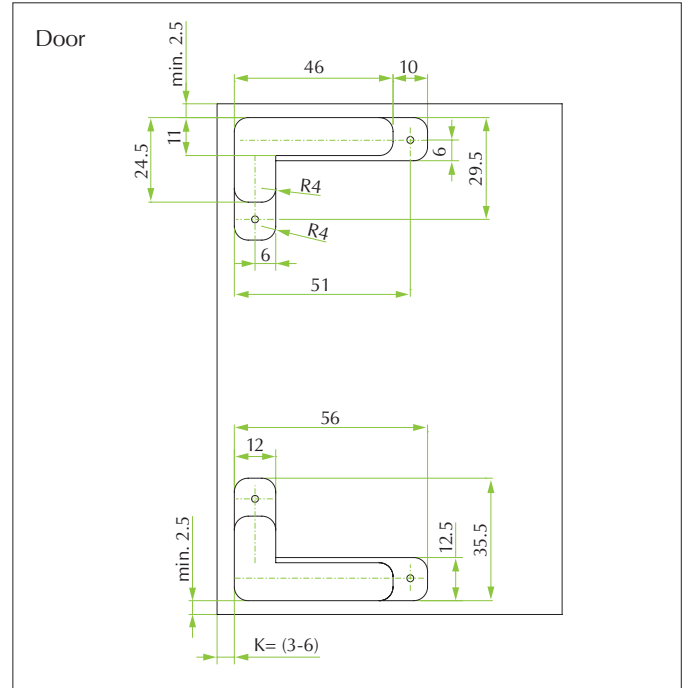
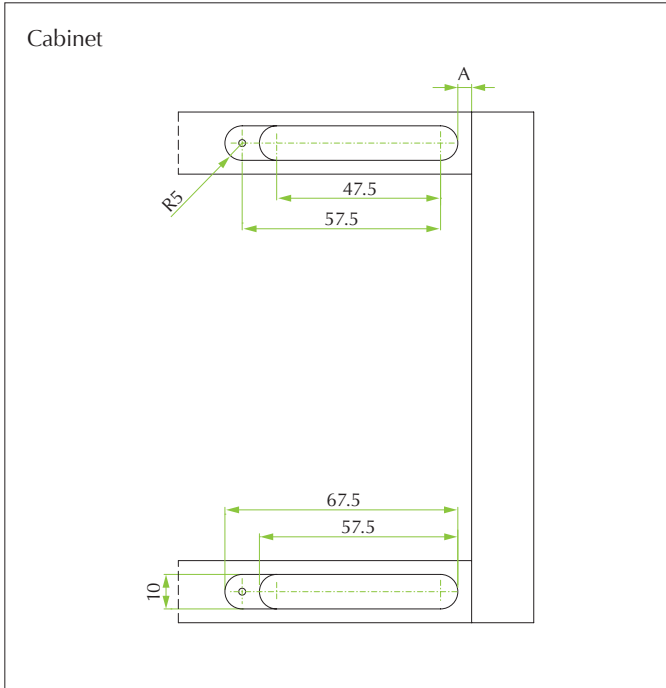

Table to determinate the minimum distance A so that a door with T thickness can open without protrusion from the cabinet and without interfering with adjacent doors.

T=	18	20	22	24	26	28	30	32
K=3 A=	0	0.2	0.5	0.9	1.4	2.1	3.1	4.7
K=4 A=	0	0.2	0.5	0.9	1.4	2.0	2.9	4.2
K=5 A=	0	0.2	0.5	0.8	1.3	2.0	2.8	3.9
K=6 A=	0	0.2	0.5	0.8	1.3	1.9	2.7	3.7

Wooden door application



Aluminium door application

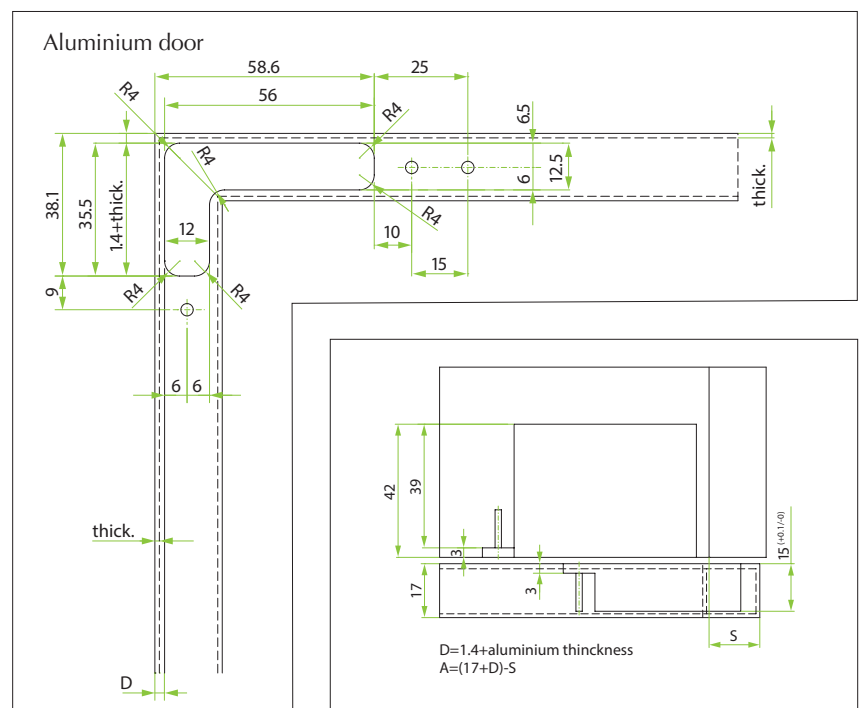
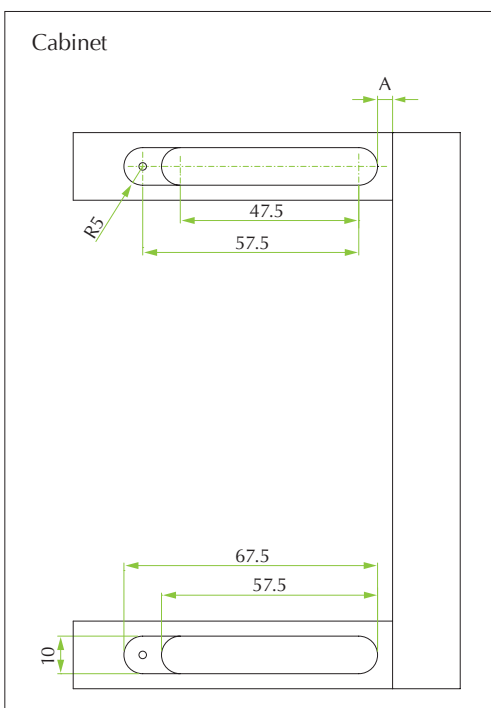

Adjustments

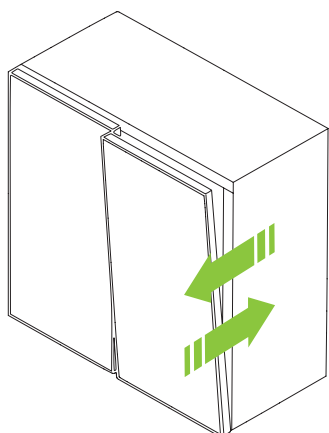

Frontal adjustments $\pm 2/-0.5$ mm

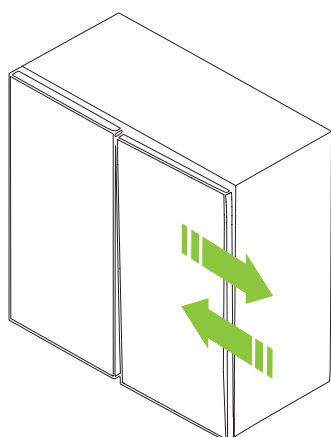
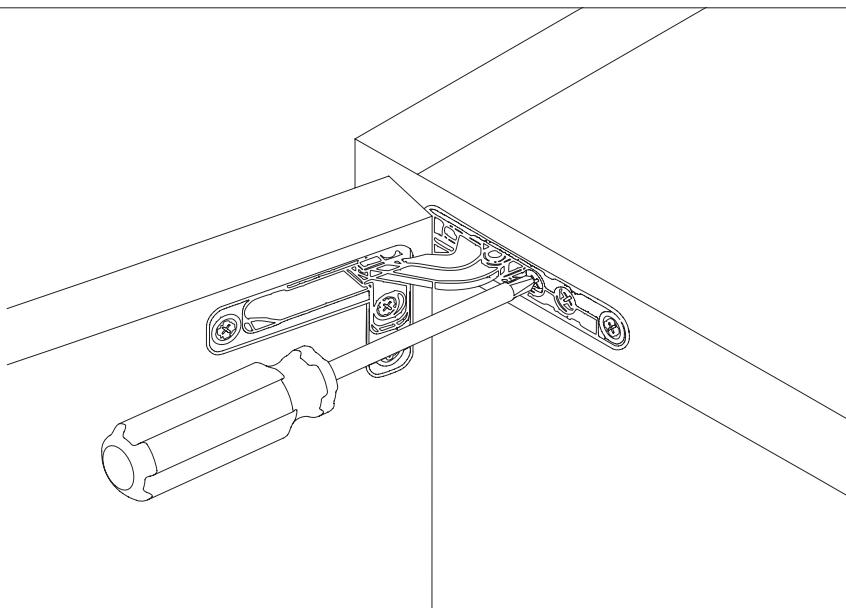

Lateral adjustments $\pm 2/-2$ mm

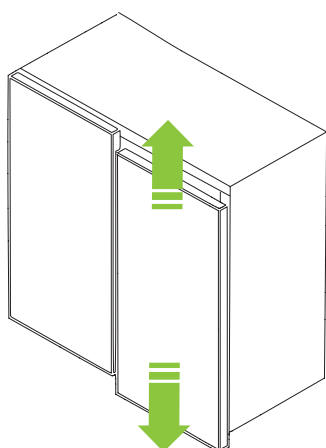
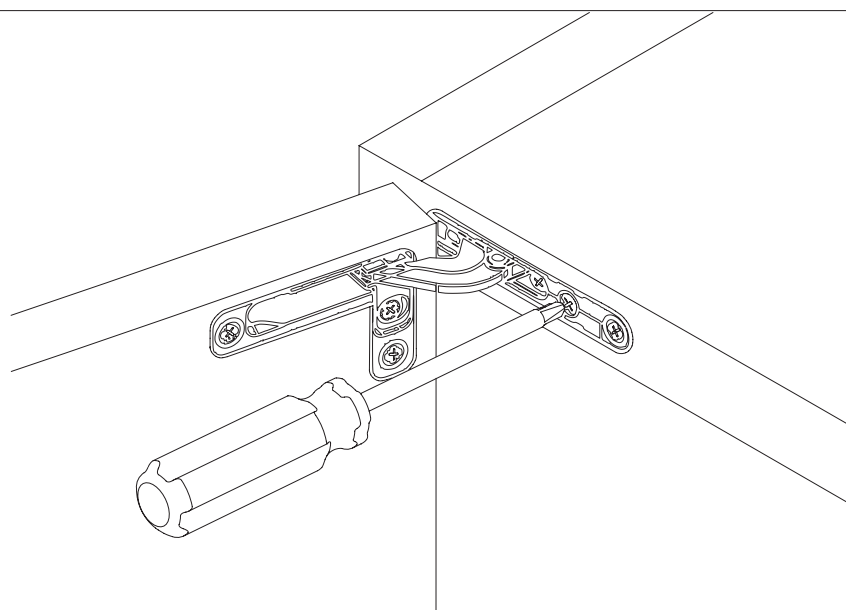

Vertical adjustments $\pm 1.5/-1.5$ mm

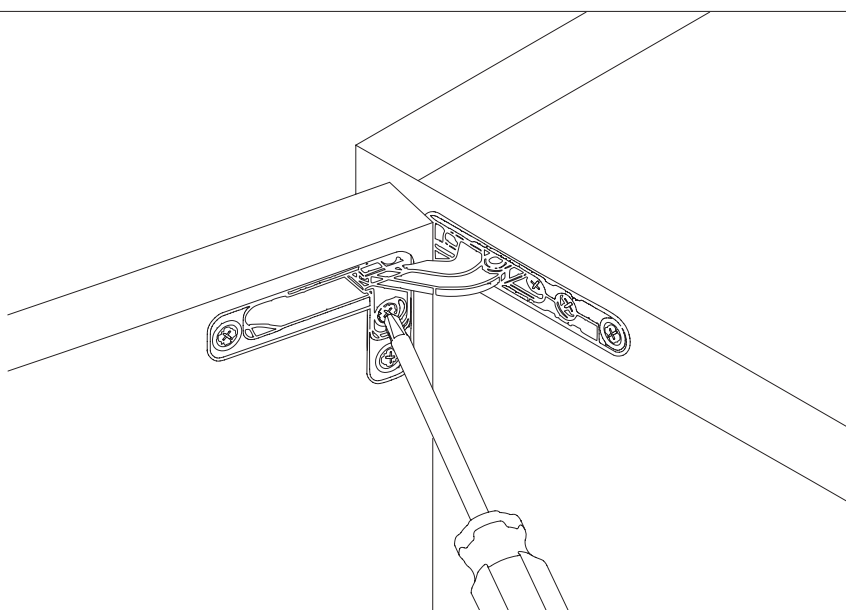

Libera XL cover cap with FGV logo

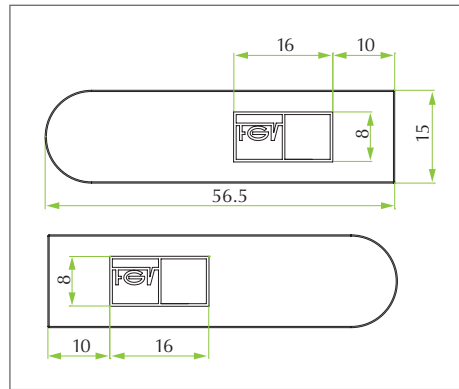
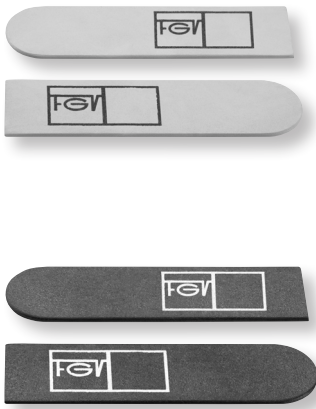

Code	Description	Packing
51.MAS2.**.KT00.000	Set of cover caps with FGV logo	500 sets

** plastic colour codes: 03 = Black / 05 = grey Nickel

Packing in set consisting of 1 box with: 1 bag of 500 right cover caps and 1 bag of 500 left cover caps.

Libera XL cover cap without logo

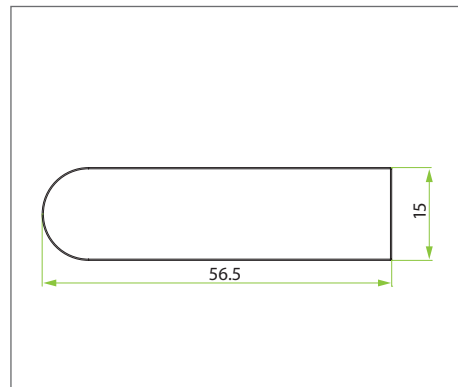

Code	Description	Packing
51.MAS2.**.0000.00N	Cover cap without logo	1000 pcs

** plastic colour codes: 03 = Black / 05 = grey Nickel

Libera XL corner connectors for aluminium framed door



Code	Description	Packing
51.0ASQ.28.0100.000	Left/Down (or Right/Up) corner connector	30 pcs
51.0ASQ.28.0200.000	Left/Up (or Right/Down) corner connector	30 pcs

Libera cover cap with FGV logo

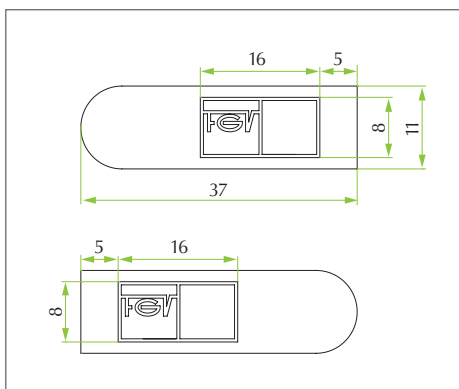
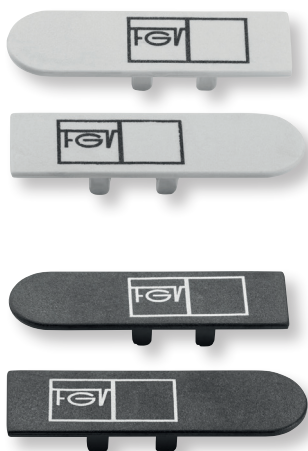

Code	Description	Packing
51.MAS1.**.KT00.000	Set of cover caps with FGV logo	500 sets

** plastic colour codes: 03 = Black / 05 = grey Nickel

Packing in set consisting of 1 box with: 1 bag of 500 right cover caps and 1 bag of 500 left cover caps.

Libera cover cap without logo

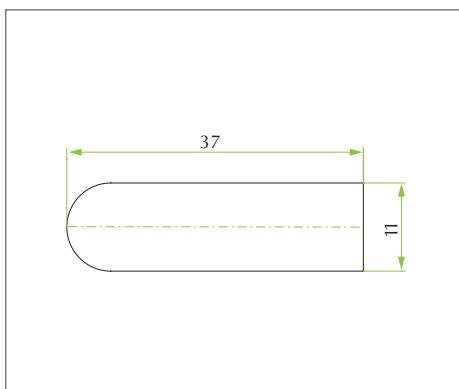

Code	Description	Packing
51.MAS1.**.0000.00N	Cover cap without logo	1000 pcs

** plastic colour codes: 03 = Black / 05 = grey Nickel

Libera corner connectors for aluminium framed door



Code	Description	Packing
51.0ASQ.08.KT00.000	Set of Up and Down corner connectors	500 sets
51.0ASQ.08.0100.000	Left/Down (or Right/Up) corner connector	100 pcs
51.0ASQ.08.0200.000	Left/Up (or Right/Down) corner connector	100 pcs

Packing in set consisting of 1 box with: 1 bag of 50 Up corner connectors and 1 bag of 50 Down corner connectors.

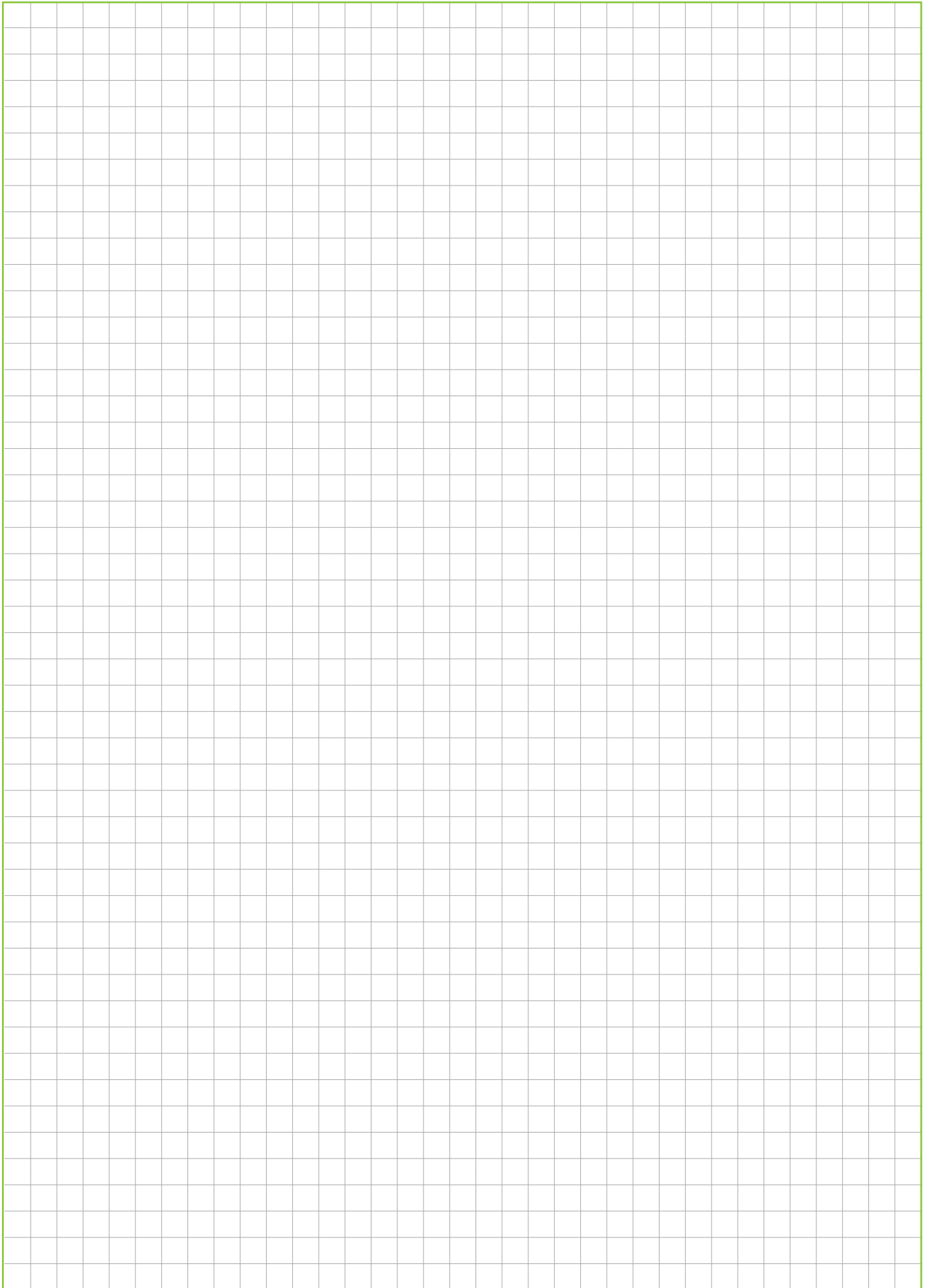

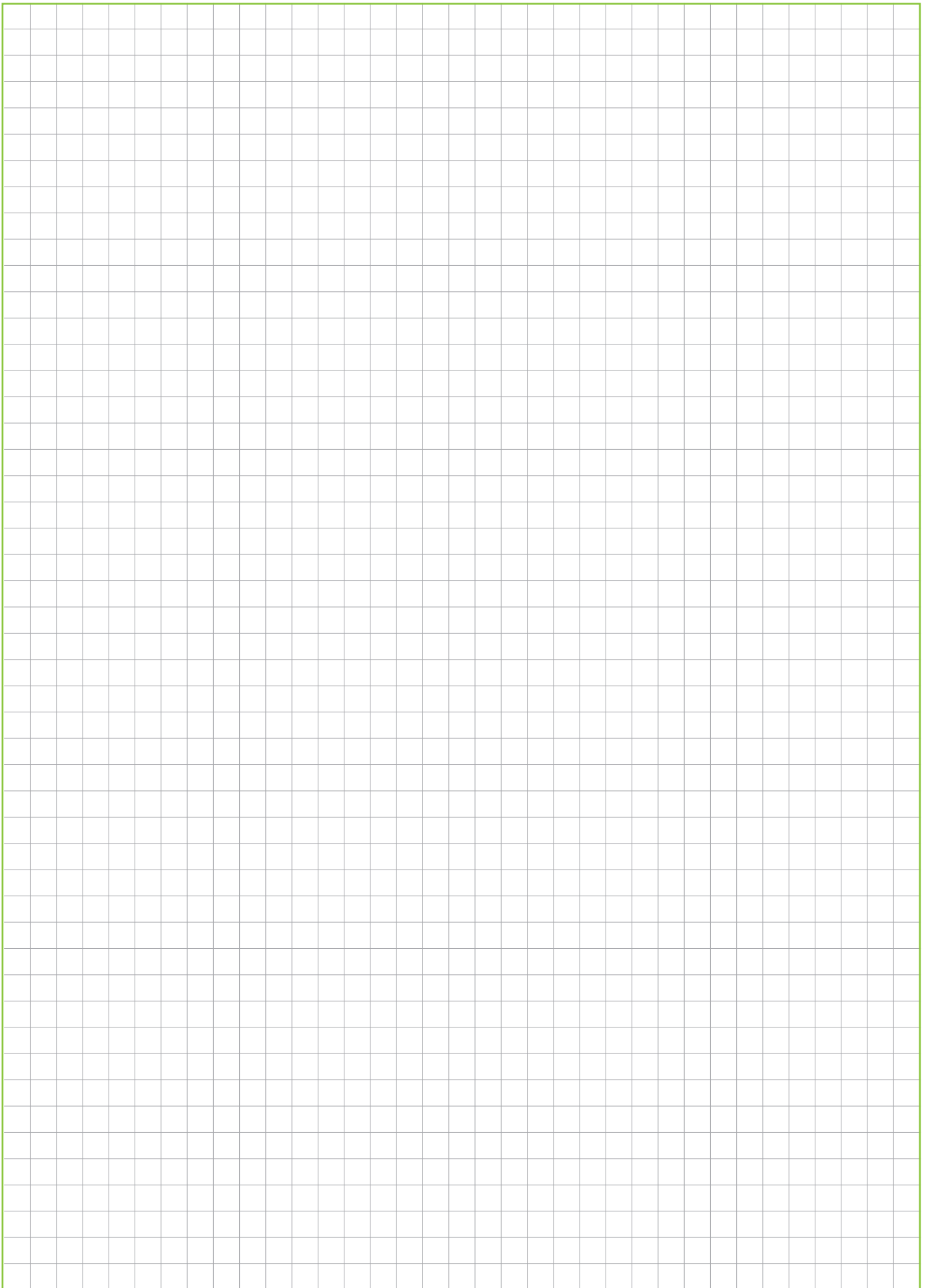



FORMENTI & GIOVENZANA S.p.A.
Via Concordia, 16
20837 Veduggio con Colzano (MB) - ITALY
Tel. +39 0362 947.1 r.a. - Fax +39 0362 998788
info@fgv.it
www.fgv.it

FGV AMERICA

California / Los Angeles Headquarters
West Coast Warehouse – River Plate
Canoga Park, CA 91304
Tel. +1 714.257.5317
info@fgvamerica.com - www.fgvamerica.com

FGVTN BRASIL LTDA.

Rua Francisco Derosso, 1352
Curitiba Paraná 81710 000 - BRASIL
Tel. +55 41 2107 4411 - Fax +55 41 3275 3038
fgvtn@fgvtn.com.br - www.fgvtn.com.br

FGV ASIA Limited

Unit 1602, 16/F., Metropolis Tower
10 Metropolis Drive, Hunghom,
Kowloon, Hong Kong - P.R.CHINA
Tel. +852 2762 1534 - Fax +852 2648 7389
info@fgvasia.com - www.fgvasia.com

FGV (Guangzhou) Company Limited

Units 2710-2711, Yang Cheng International Trading Centre
East Tower, Ti Yu Dong Lu, No. 122
Guangzhou - P R CHINA
Tel. +86 20 38870570 - Fax +86 20 38870323
info@fgvchina.com - www.fgvchina.com

FORMENTI & GIOVENZANA EUROPE

Ul. Boleslawiecka 8a
98-400 Wieruszów - POLAND
Tel. +48 62 58 10 400 - Fax +48 62 58 10 480
biurofgv@fgveurope.com

FGV SERVICE VENETO S.r.l.

Via Pietro Bassani, 12
33170 Pordenone (PN) – ITALY
Tel. +39 0434 572728
info@fgvserviceveneto.com

FGV SERVICE CENTRO-SUD

Via Massimo d'Antona, 6i
60033 Chiaravalle (AN) - ITALY
Tel. +39 071 7451125 - Fax +39 071 7496441
infocentrosud@fgvservice.com